



**Columbia County
Highway “V”**

Public Involvement Meeting

August 9, 2018



AVRES
ASSOCIATES

Project Team

- **Columbia County**
 - Chris Hardy, Highway and Transportation Commissioner
- **Design Team**
 - Dan Schrum, Ayres Associates
 - Eric Sorensen, Ayres Associates
- **Wisconsin Department of Transportation's Management Consultant Representatives**
 - Bill Biesmann, KL Engineering
 - Mark Westerveld, WisDOT

Topics

- Project History
- Current Project Limits
- Purpose and Need
- Project Overview
- Project Elements
- Real Estate
- Construction
- Schedule



Project History

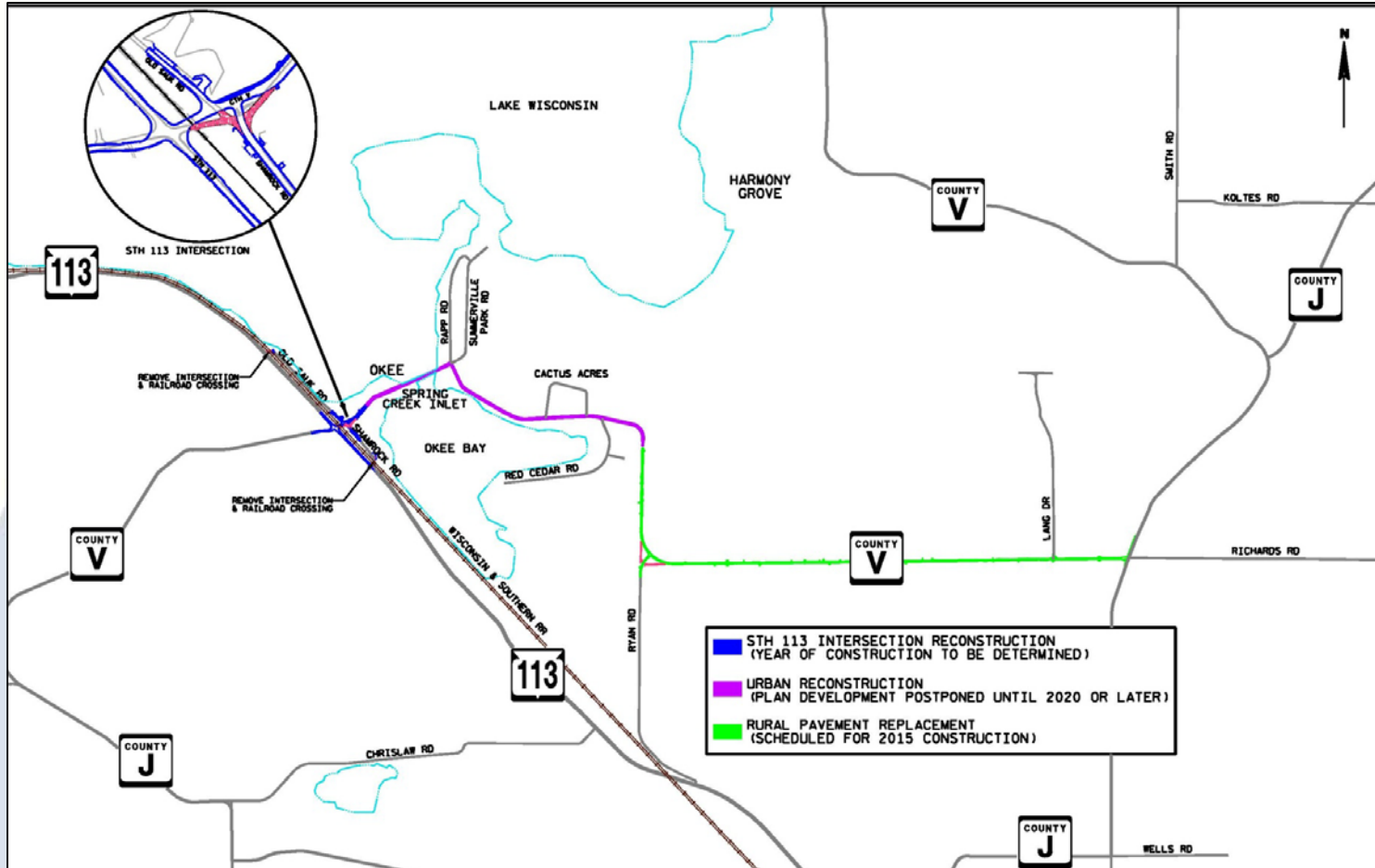

Current Project Limits



- STH 113 to Rapp Road
- Pavement Reconstruction
- Intersection Realignment
- Re-deck of the Bridge on the Causeway

Project Purpose and Need

- Address deteriorating pavement, roadside drainage and deteriorating bridge deck on the Spring Creek Inlet bridge
- The need is defined by the physical, structural and geometric deficiencies along with social demands

Project Purpose and Need



Project Overview



Project Elements - Intersections

- STH 113 Intersection
- RR Crossing
- Old Sauk and Shamrock Roads Intersection
- Realignment

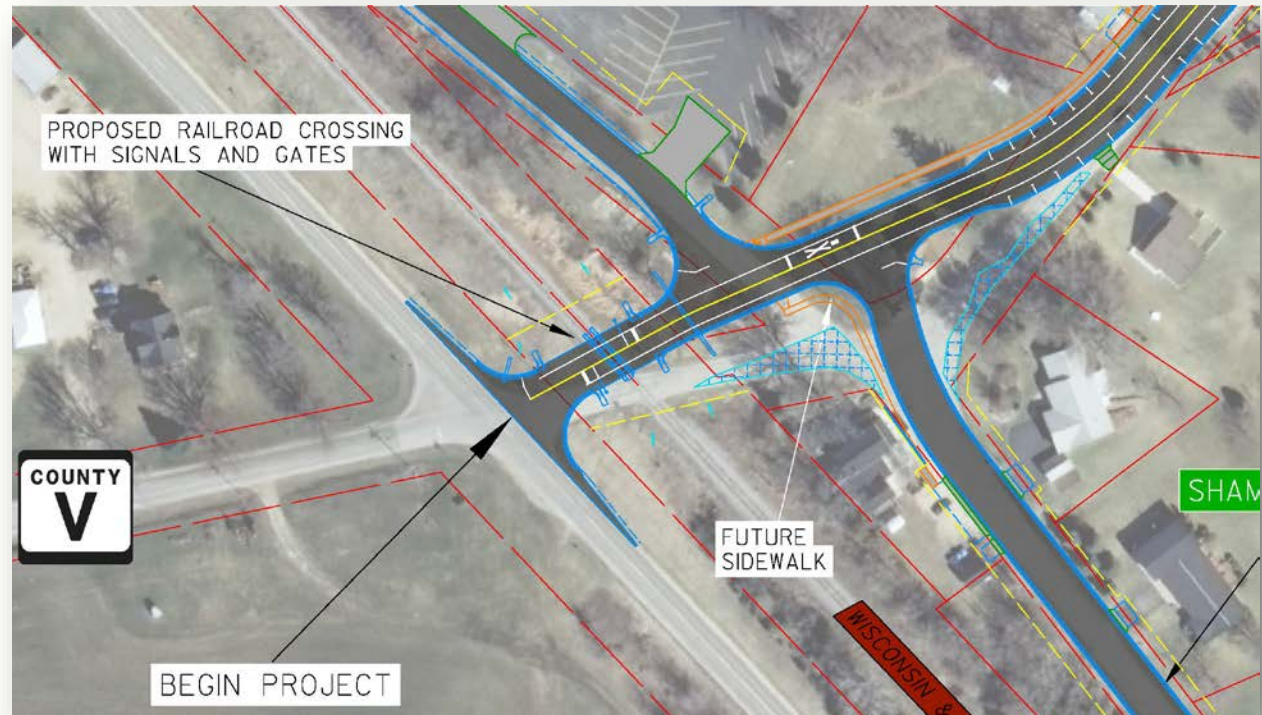

Project Elements – CTH V

- On-street parking
- Bike and pedestrian accommodations
- Curb and gutter



Project Elements - Causeway

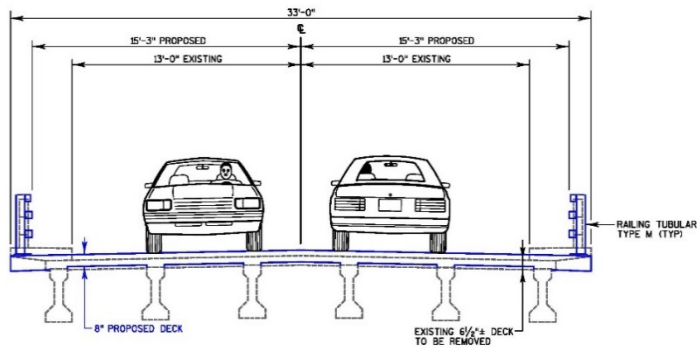

TYPICAL FINISHED SECTION CTH V THRU BRIDGE

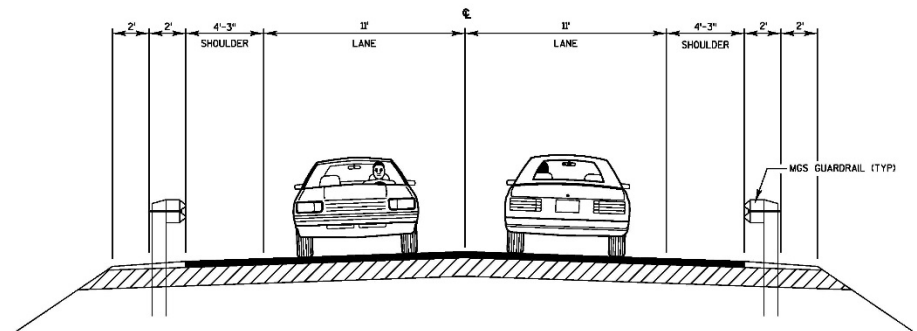

TYPICAL FINISHED SECTION CTH V W/GUARDRAIL

Real Estate

- Right of way acquisition
- What is a Temporary Limited Easement (TLE)?
- Who will I talk to?
- When will the process start?



Project Construction - 2019

- Construction schedule start after July 4th weekend, completed by mid-October 2019.
 - Removals – pavement
 - Underground work storm sewer
 - Concrete curb and gutter, sidewalk and driveways
 - Railroad crossing
 - Bridge work
 - Asphalt paving
 - Signing and Marking
 - *Note: Activities such as utility relocations and tree removal will most likely occur prior to the contractor start date*



Project Construction - 2019

- CTH V – closed to through traffic with a signed detour in place
 - Locals and businesses will still have access
 - 2 complete closures
 - Structure work – after Labor Day for several weeks
 - Railroad crossing work ~ 3 weeks
 - Old Sauk and/or Shamrock would be required to remain open to STH 113



Project Construction - 2019

- Concerns during construction
 - Who do I talk to?
 - Accessing driveways
 - Parking
 - Mail
 - Fire Numbers



Design Schedule

- Preliminary Design (30%) Spring 2017
- Public Meeting Fall 2017
- Environmental Document Winter 2017/18
- Preliminary Design (60%) Winter 2017/18
- **Public Meeting** **Summer 2018**
- Begin Acquisition of Easements Summer 2018
- Final Design Plans Fall 2018
- Construction Summer 2019 to Fall 2019



Thank You!

Please fill out a comment form

Your input, participation and comments
are appreciated

Project Contact

Email address:

SchrumD@AyresAssociates.com